

Surface Mount 2-Electrode Gas Discharge Tube (GDT)

UN2E5-SMD Series

Description

Gas discharge Tubes (GDT) are classical components for protecting the installations of the telecommunications. It is essential that IT and telecommunications systems -with their high-grade but sensitive electronic circuits - be protected by arresters. They are thus fitted at the input of the power supply system together with varistors and at the connection points to telecommunication lines. They have become equally indispensable for protecting base stations in mobile telephone systems as well as extensive cable television (CATV) networks with their repeaters and distribution systems.

These protective components are also indispensable in other sectors, In AC power transmission systems, they are often used with current-limiting varistors, In customer premises equipment such as DSL modems, WLAN routers, TV sets and cable modems In air-conditioning equipment, the integral black-box concept offers graduated protection by combining arresters with varistors, PTC, diodes and inductor.

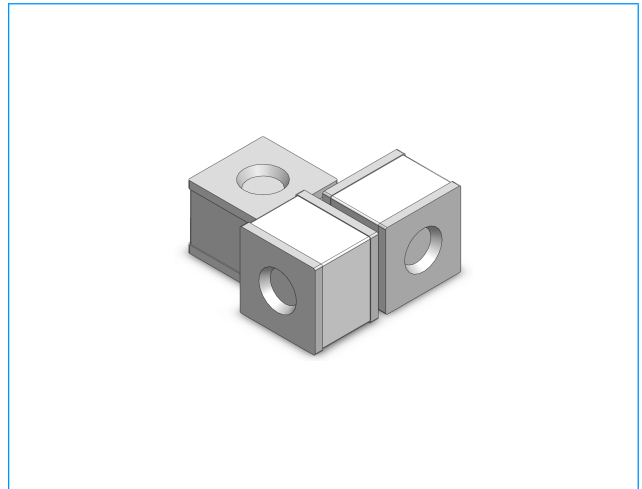

Schematic Symbol

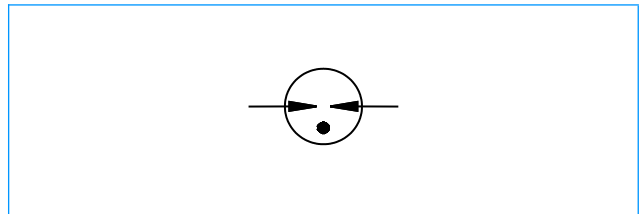

Agency Approvals

- u Non-Radioactive
- u RoHS compliant
- u Low insertion loss
- u Excellent response to fast rising transients
- u Ultra low capacitance
- u 5KA surge capability tested with 8/20µs pulse as defined by IEC 61000-4-5

Applications

- u Communication equipment
- u CATV equipment
- u Test equipment
- u Data lines
- u Power supplies
- u Telecom SLIC protection
- u Broadband equipment
- u ADSL equipment, including ADSL2+
- u XDSL equipment
- u Satellite and CATV equipment
- u Consumer electronics

Product Characteristics

Materials	Dull Tin-plated
Product Marking	Without
Glow to Arc Transition Current	< 0.5 Amps
Glow Voltage	~60 Volts
Storage and Operational Temperature	-40 to +90°C
Weight	~0.5g
Climatic category (IEC 60068-1)	40/ 90/ 21

Surface Mount 2-Electrode Gas Discharge Tube (GDT)

UN2E5-SMD Series

Device Dimensions (Unit: mm)

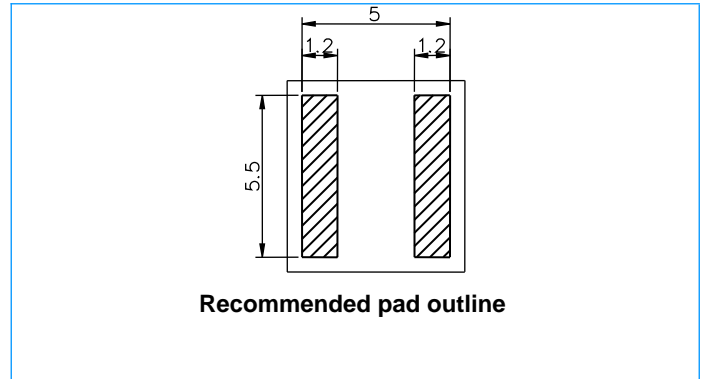
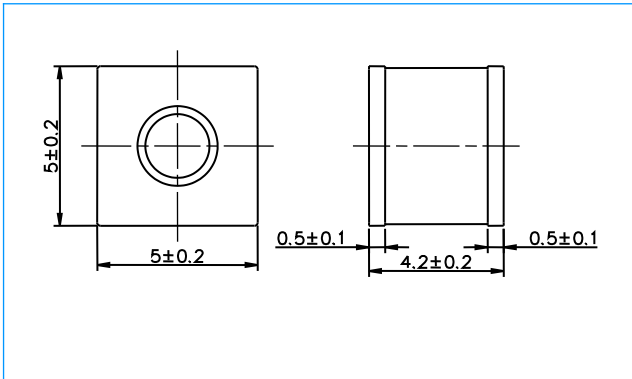

Electrical Characteristics

Part Number	DC Spark-over Voltage	Maximum Impulse Spark-over Voltage		Minimum Insulation Resistance	Maximum Capacitance	Arc Voltage	Service Life			
		@100V/μs	@1KV/μs				Nominal Impulse Discharge Current	Max Impulse Discharge Current	Nominal Alternating Discharge Current	Impulse Life
	@100V/S	@100V/μs	@1KV/μs		@1MHz	@1A	@8/20μs ±5 times	@8/20μs 1 time	@50Hz 1 Sec 10 times	@10/1000μs 300 times
UN2E5-90LSMD	90V±20%	<500V	<650V	1 GΩ (at 50V DC)	<1.0pF	~15V	5KA	10KA	5A	100A
UN2E5-150LSMD	150V±20%	<500V	<650V	1 GΩ (at 50V DC)	<1.0pF	~20V	5KA	10KA	5A	100A
UN2E5-200LSMD	200V±20%	<500V	<650V	1 GΩ (at 100V DC)	<1.0pF	~20V	5KA	10KA	5A	100A
UN2E5-230LSMD	230V±20%	<600V	<700V	1 GΩ (at 100V DC)	<1.0pF	~20V	5KA	10KA	5A	100A
UN2E5-300LSMD	300V±20%	<700V	<800V	1 GΩ (at 100V DC)	<1.0pF	~20V	5KA	10KA	5A	100A
UN2E5-350LSMD	350V±20%	<700V	<800V	1 GΩ (at 100V DC)	<1.0pF	~20V	5KA	10KA	5A	100A
UN2E5-420LSMD	420V±20%	<800V	<950V	1 GΩ (at 100V DC)	<1.0pF	~20V	5KA	10KA	5A	100A
UN2E5-470LSMD	470V±20%	<900V	<1000V	1 GΩ (at 100V DC)	<1.0pF	~20V	5KA	10KA	5A	100A
UN2E5-600LSMD	600V±20%	<1100V	<1200V	1 GΩ (at 100V DC)	<1.0pF	~20V	5KA	10KA	5A	100A

Notes:

1. Terms in accordance with ITU-T K.12 and GB/T 9043-2008
2. At delivery AQL 0.65 level II, DIN ISO 2859

Surface Mount 2-Electrode Gas Discharge Tube (GDT)

UN2E5-SMD Series

Electrical Rating

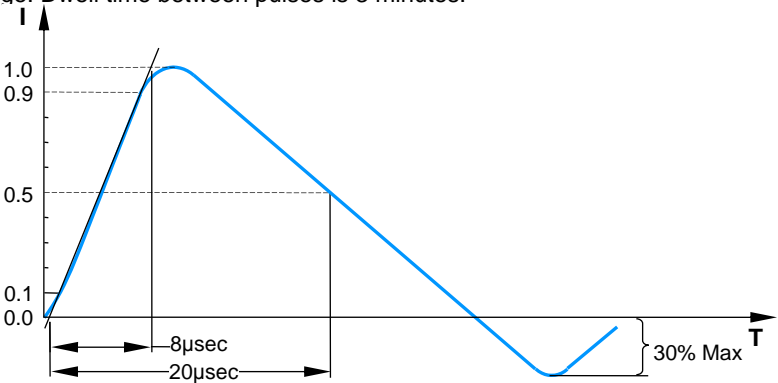
Item	Test Condition / Description	Requirement
DC Spark-over Voltage	The voltage is measured with a slowly rate of rise $dv / dt=100V/s$	To meet the specified value
Impulse Spark-over Voltage	The maximum impulse spark-over voltage is measured with a rise time of $dv / dt=100V/\mu s$ or $1KV/\mu s$	
Insulation Resistance	The resistance of gas tube shall be measured each terminal each other terminal, please see above spec.	
Capacitance	The capacitance of gas tube shall be measured each terminal to each other terminal. Test frequency :1MHz	
Nominal Impulse Discharge Current	The maximum current applying a waveform of 8/20 μs that can be applied across the terminals of the gas tube. One hour after the test is completed, re-testing of the DC spark-over voltage does not exceed $\pm 30\%$ of the nominal DC spark-over voltage. Dwell time between pulses is 3 minutes. 	
Nominal Alternating Discharge Current	Rated RMS value of AC current at 50Hz, 1 sec. 10 times. Intervals: 3min. The DC spark-over voltage does not exceed $\pm 30\%$ of the nominal DC spark-over voltage. $IR > 10^8\text{ohms}$.	

Recommended soldering profile

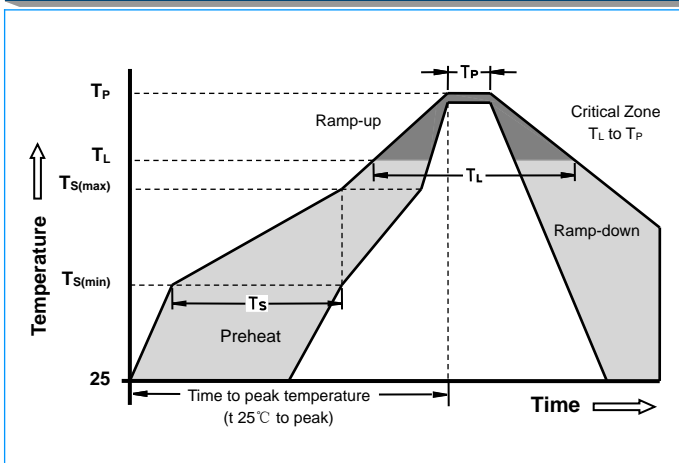

Reflow Condition		Pb - Free assembly
Pre Heat	- Temperature Min ($T_{s(min)}$)	150°C
	- Temperature Max ($T_{s(max)}$)	200°C
	- Time (min to max) (t_s)	60 -180 Seconds
Average ramp up rate (Liquidus Temp T_L) to peak		3°C/second max
$T_{s(max)}$ to T_L - Ramp-up Rate		5°C/second max
Reflow	- Temperature (T_L) (Liquidus)	217°C
	- Time (min to max) (t_s)	60 -150 Seconds
Peak Temperature (T_P)		260 +0/-5°C
Time within 5°C of actual peak Temperature (t_p)		10 - 30 Seconds
Ramp-down Rate		6°C/second max
Time 25°C to peak Temperature (T_P)		8 minutes Max
Do not exceed		260°C

Surface Mount 2-Electrode Gas Discharge Tube (GDT)

UN2E5-SMD Series

Part Numbering

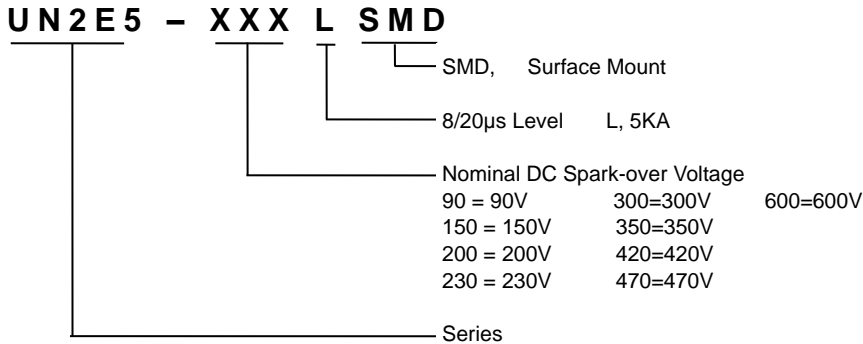

Tape and Reel Dimensions Unit: mm

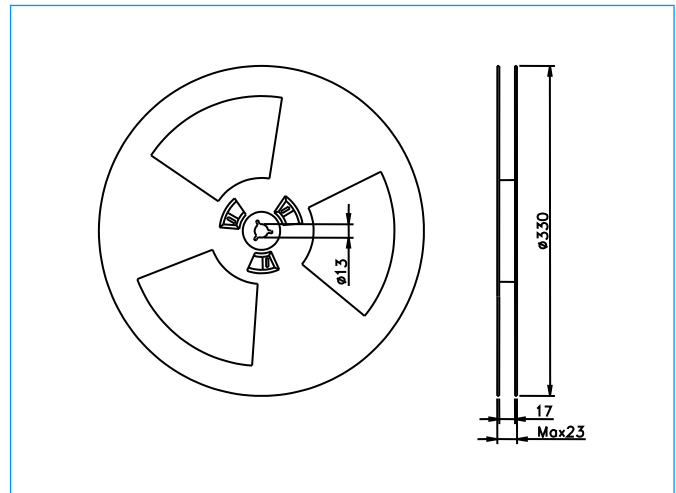
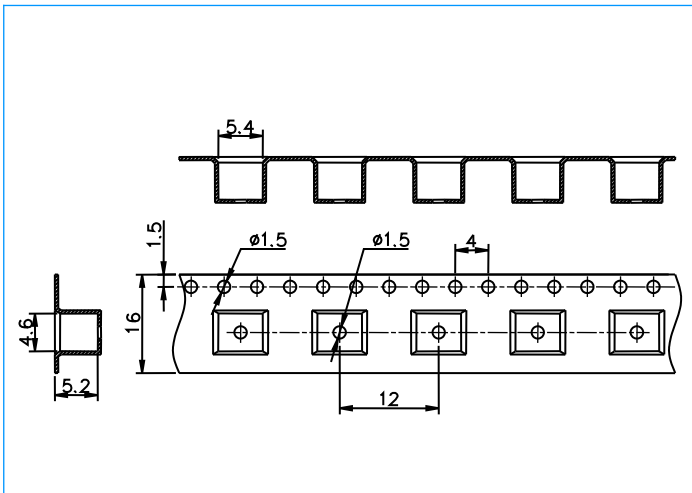

Packaging

Part Number	Packaging Option	Quantity
UN2E5-XXXLSMD	Tape & Reel -16mm tape/13"Reel	1000

Cautions and warnings

- ⚠ Gas discharge tubes (GDT) must not be operated directly in power supply networks.
- ⚠ Gas discharge tubes (GDT) may become hot in case of longer periods of current stress (danger of burning).
- ⚠ Gas discharge tubes (GDT) may be used only within their specified values. In the event of overload, the head contacts may fail or the component may be destroyed.
- ⚠ Damaged Gas discharge tubes (GDT) must not be re-used.